

PRODUCT DATA

CE VH-5409 Wireless Zoom Pedal type LC

General specifications:

Power input: 4x AAA Alkaline batteries

Weight: 747 g

Frequency: 433 mHz

Max distance available: ± 100 mtr

Estimated battery life: 5 years

Housing material: ABS plastic

Housing dimensions: 196x142x36,25mm (LxWxH)

Functionality:

Our wireless zoom pedal controls the build-in zoom & tilt functions integrated in our camera's.

In addition, the camera can be turned on and off using the zoom pedal.

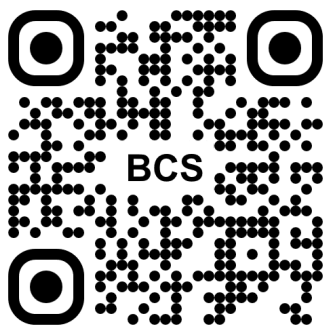
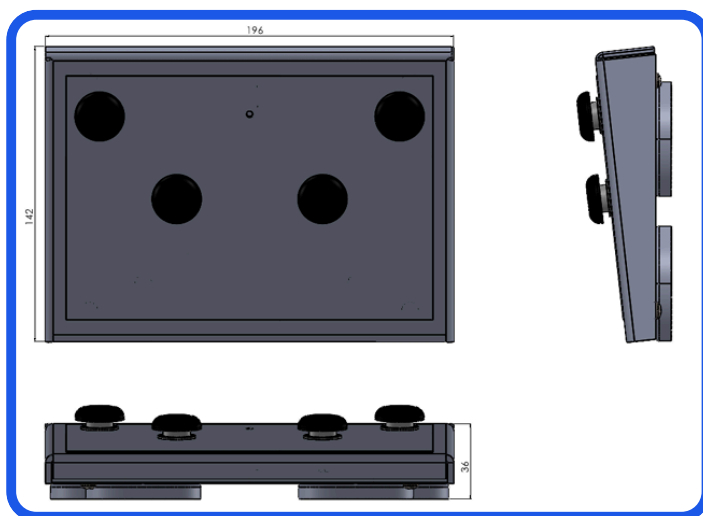

More Information:

✉ info@cranecamera.eu

🌐 www.cranecamera.eu

Office: ☎ +31 33 466 8938

Service: ☎ +31 6 159 561 05



BCS
CRANECAMERA