

# PRODUCT DATA



## VH-9660 Battery Pack type TC

### General specifications:

**Output:** ~12,6V DC

**Weight:** 9Kg

**Capacity:** 26 Ah

**Type:** 12V-26A- Cyclic AGM Battery (Lead-acid)

**Housing material:** Aluminum and Carbon

**Housing dimensions:** 236x102x222,5mm (LxWxH)

### Functionality:

This battery unit supplies power to the trolley camera system, ensuring continuous operation and reliable performance when using in combination with the solar panel VH-9680.

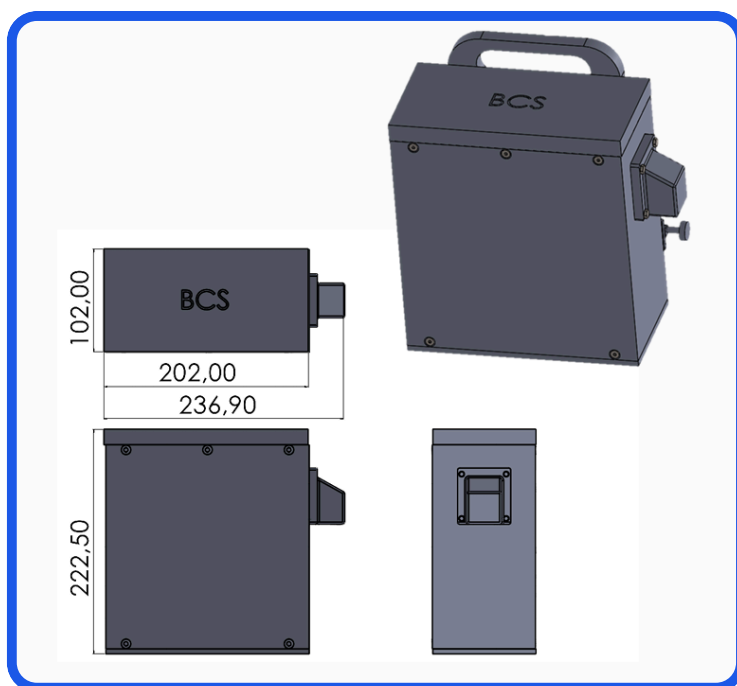

### More Information:

✉ [info@cranecamera.eu](mailto:info@cranecamera.eu)

🌐 [www.cranecamera.eu](http://www.cranecamera.eu)

Office: ☎ +31 33 466 8938

Service: ☎ +31 6 159 561 05

**BCS**  
CRANECAMERA